

# Installation Instructions for 10W and 5W Projector Lamp

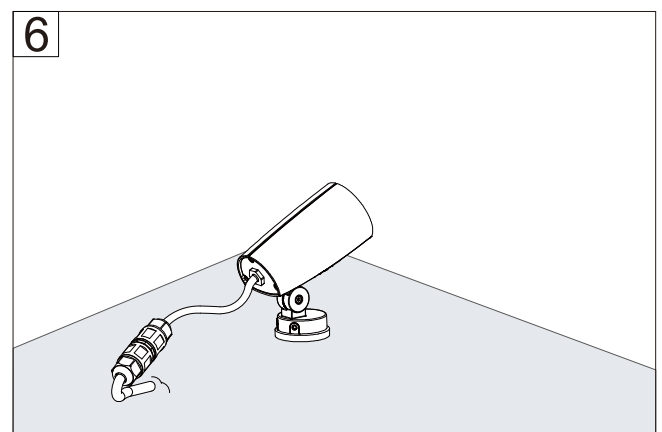

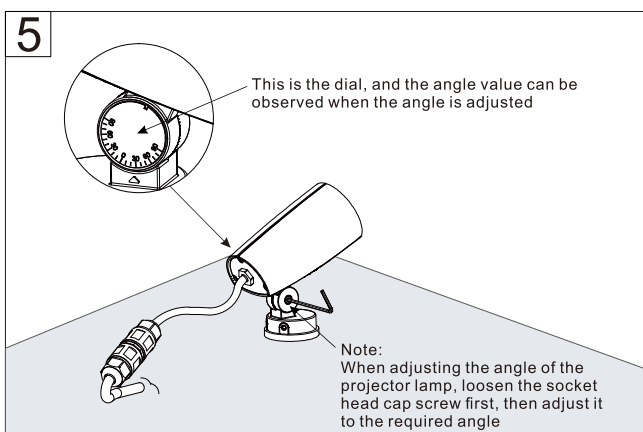

# Installation Instructions for 10W and 5W Projector Lamp (with earth spike)

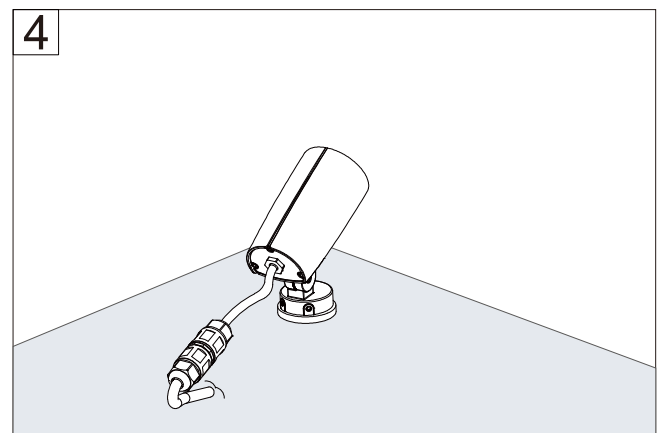
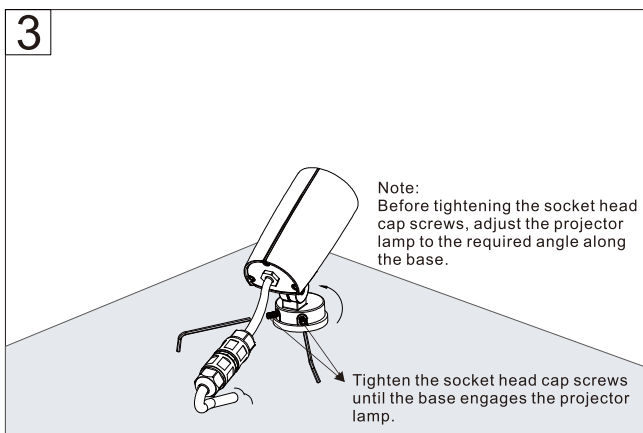
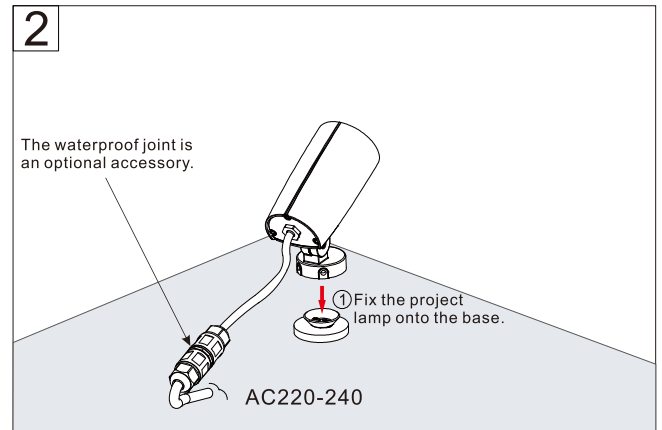
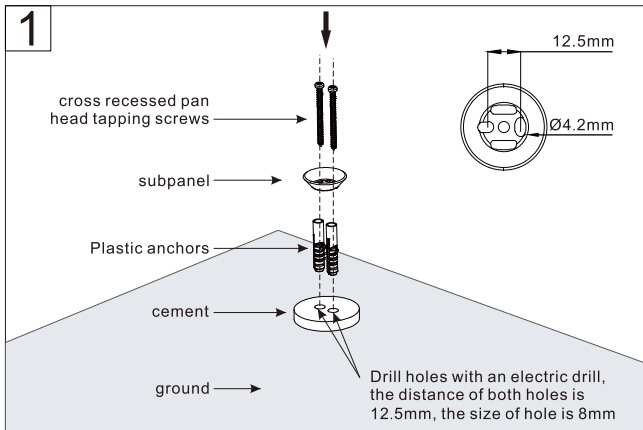
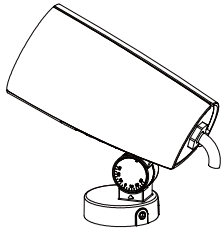