

Our Equo-P pendant light design embodies a minimalist, stylish, and imaginative concept, employing exquisite process and rigorous material selection standards to achieve a richly textured appearance. The optical module comprises microstructured optical lenses and anti-glare louvre, with UGR < 13. Comfortable and soft light distribution is achieved through different beam angles (75° for direct light and 155° for indirect light). Typical luminous efficacy reaches 135 lm/W, flicker free. It supports DIP switch in CCT and power. Linkable optional. The main materials are aluminum, steel, and PC.

Features

Simple and rich textured design

Light efficiency up to 135lm/W

$L_{max} \geq 65^\circ < 1000 \text{ cd/m}^2$

Ultimate uniform and quality lighting effects with professional glare control, UGR < 13

Linkable design provide a clean, simple link

Direct and Indirect lighting

5 years warranty

Application Areas

For open-plan office, Individual office, meeting room, Guest room , etc..



Technical data

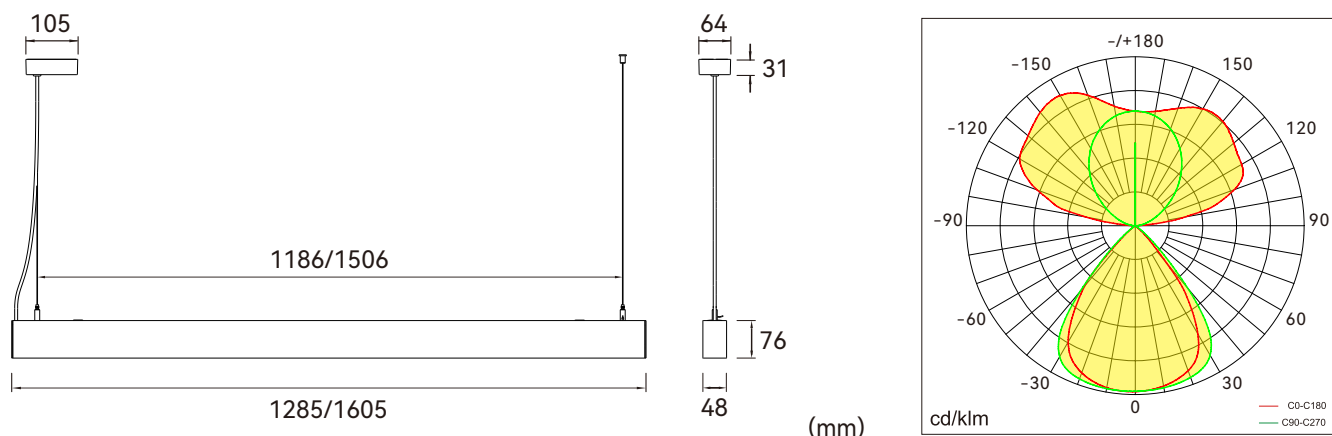

Item No.	BEQP-1206024-NN	BEQP-1206024-DN	BEQP-1507028-NN	BEQP-1507028-DN
Input Power(±10%)	50W (↑ 30W/20W ↓) / 60W (↑ 36W/24W ↓) power switchable		60W (↑ 36W/24W ↓) / 70W (↑ 42W/28W ↓) power switchable	
Input Voltage	AC200~240V			
Power Factor	≥0.9			
Luminous Flux(±10%)	6750lm (↑ 4350lm/2400lm ↓) (50W) 8000lm (↑ 5200lm/2800lm ↓) (60W)		8100lm (↑ 5400lm/2700lm ↓) (60W) 9300lm (↑ 6150lm/3150lm ↓) (70W)	
UGR	<13			
Color Rendering Index	>80			
Life Time	L80(B10)50,000H			
Beam Angle	↑ 155°/75° ↓			
CCT(±200K)	3000/4000K CCT switchable			
Colour consistency SDCM	<3			
Dimming	On/off	DALI dimming	On/off	DALI dimming
Sensor	NO			
Housing Color	Silver / White / Black			
Fixture Materia	6063AL			
Protection Level	IP20			
Storage Temperature	-40°C~+60°C			
Working Temperature	-20°C~+40°C			
Net Weight	2.8kg			
Gross Weight	8.4kg (2Pcs)			
Package size	1430*236*150mm			
20GP	1200 Pcs			
40GP	2450 Pcs			
40HQ	2700 Pcs			

Packaging

1.2m

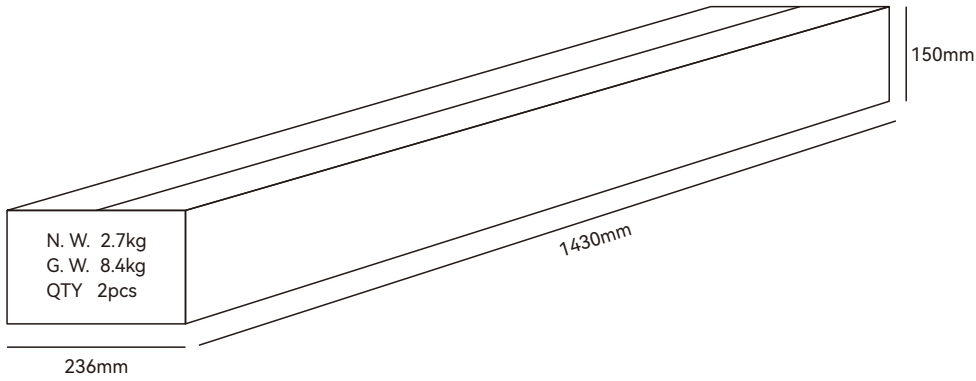

Shenzhen Nexol Lighting Technology Co.,Ltd.

E-mail: info@nexol-lighting.com

www.nexol-lighting.com

Factory: Floor 6-9, Building 3, Tonghu Intelligent Industrial Park, Zhongkai High-Tech District, HuiZhou 516035

Office: Room 306&309, Floor 3, Building E, Longhua Digital Industrial Park, Guanlan Road 54-6, Longhua district, Shenzhen, China 518110



All values in specification are typical value from laboratory measurement, for concrete data, please refer to shipment testing report. Information provided is subject to change without notice. Please verify all details with NEXOL Lighting.

Copyright Shenzhen Nexol Lighting Co., Ltd.. All rights reserved.